

INDUCED POLARIZATION TRVERSE
SECTIONAL DATA SHEET
for
NORTH AMERICAN MINES

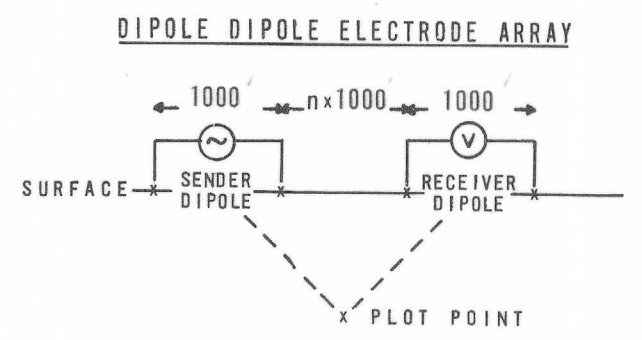
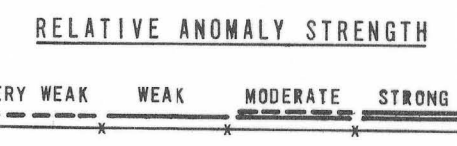

AREA
CUPRITE MINE
LOOKING
SW 1/2 - N 23 W
NE 1/2 - N 28 W
DATE
APRIL 1971

HEINRICHS
GEOEXPLORATION COMPANY

AUSTRALIA U.S.A.
(SYDNEY) Post Office Box 5964
39 Hume Street Tucson, Arizona 85703
GEOPHYSICAL Crows Nest, NSW Phone: (602) 623-0578
ENGINEERS Phone: 439-1793 Cable: GEOEX, Tucson

