

589-70

LINE NO.
15W
SPREAD(S)
1 & 2

INDUCED POLARIZATION TRAVERSE
SECTIONAL DATA SHEET
for
ST. JOE MINERALS CORPORATION

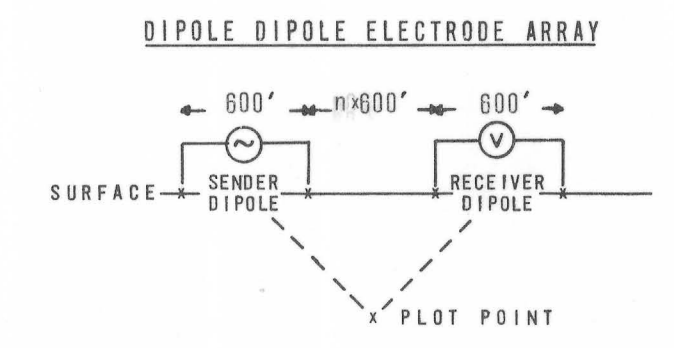
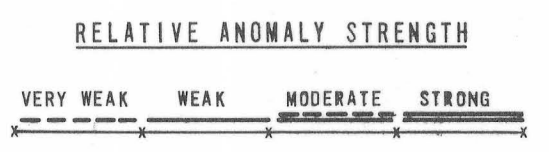

AREA
NORTH BUTTE

LOOKING
WEST

DATE
DEC 1970

HEINRICHS
GEOEXPLORATION COMPANY

AUSTRALIA (SYDNEY)
39 Hume Street
Crows Nest, NSW
Phone: 439-1793

U.S.A.
Post Office Box 5964
Tucson, Arizona 85703
Phone: (602) 623-0578
Cable: GEOEX, Tucson